

Why use a Flame Arrester?

Protecting People, Property and our Planet.

An introduction to Elmac Technologies

Elmac Technologies® is the international leader in flame and explosion prevention systems for use in some of the world's most challenging industrial environments.

This brief guide provides an introduction to flame arresters (also arrestors) and includes a summary of their design/construction and how they work. There are useful notes explaining the different types of gases & vapours and also specific flame types and where they may occur. In addition, you will find details of the most current international flame arrester standards.

For comprehensive technical advice regarding the selection and use of flame arresters please contact:

Elmac Technologies Limited

Tel: +44 (0) 1352 717 555

Email: info@elmactech.com

Fax: +44 (0) 1352 717 642

Coast Road, Greenfield, Flintshire,
CH8 9DP United Kingdom

Definition of a Flame Arrester

A flame arrester is a device fitted to the opening of an enclosure or to the connecting pipework in a system of enclosures. They permit gases or vapours to flow but prevent the transmission of a flame should an ignition take place.

In this guide, consideration is limited to flame arresters for use where the flame burns in air i.e. not in oxygen where different considerations apply. Furthermore, the guide is restricted to passive flame arresting devices with no moving parts.

Why use a Flame Arrester?

One of the greatest dangers involved with the transport or storage of flammable liquids or gases is that ignition of the flammable vapour may occur, resulting in fire or, even worse, an explosion.

This guide sets out to introduce the subject of flame arresters, and the principles and concepts behind their specification and use. For those seeking a more detailed understanding, full technical advice and support is available from Elmac Technologies®.

Whenever a flammable gas or vapour is mixed with air (oxygen), there is the potential for an explosion. Accidental ignition of the flammable mixture will result in a flame that will travel through the unburnt mixture until the fuel is consumed by the reaction. In an enclosed space, such as a vessel or a pipe, the significant temperature increase of the mixture caused by the combustion process will lead to a rapid increase in the volume of the gas mixture. In an enclosed space the resulting increase in pressure will induce turbulent effects which will further accelerate the flame front.



< Our range of Flame Arresters comprises three main types:

1. End-of-line Deflagration Arresters
2. In-line Deflagration Arresters
3. In-line Unstable Detonation Arresters

Types of flame

and conditions where they are found

Unconfined Deflagration



An unconfined deflagration occurs when there is an ignition of a flammable atmosphere outside a container or other process equipment. For example, a breathing or ventilation outlet from a tank storing gasoline may produce an unconfined cloud of flammable vapour in its immediate vicinity. Ignition sources such as a static electrical discharge, a lightning strike or a lit cigarette could ignite this vapour cloud and the resulting flame front may enter the tank through the venting point, should the outlet not be protected by a flame arrester.

Confined Deflagration



Where a flammable mixture in a pipeline is ignited, the flame front will initially travel along the pipe at subsonic velocities in what is known as a confined deflagration. Typically this could occur in industrial or process plants. For example, many coal mines generate flammable and poisonous methane gas below ground which is pumped to the surface along a pipe and then burnt in a boiler for heating purposes. Problems with the boiler or the pumping system could ignite the pipe contents and the flame could travel back down the pipe resulting in an explosion below ground.

Detonation



A detonation occurs where a flame travels along a pipe, usually at supersonic velocities, and is associated with a shock wave. Typically this occurs as a result of compressive heat effects and flame acceleration caused by turbulent flow resulting from bends, valves or changes in section of the pipe. It can also occur simply by allowing the flame to continue to accelerate along a pipe for a sufficient distance. A shock wave is characterised by a step change in pressure and density through which the flame velocity changes from being subsonic to supersonic. This is referred to as a Deflagration to Detonation Transition or DDT.

FIGURE 1: TYPICAL EXAMPLE OF ACCELERATION OF FLAME TO DETONATION CONDITIONS

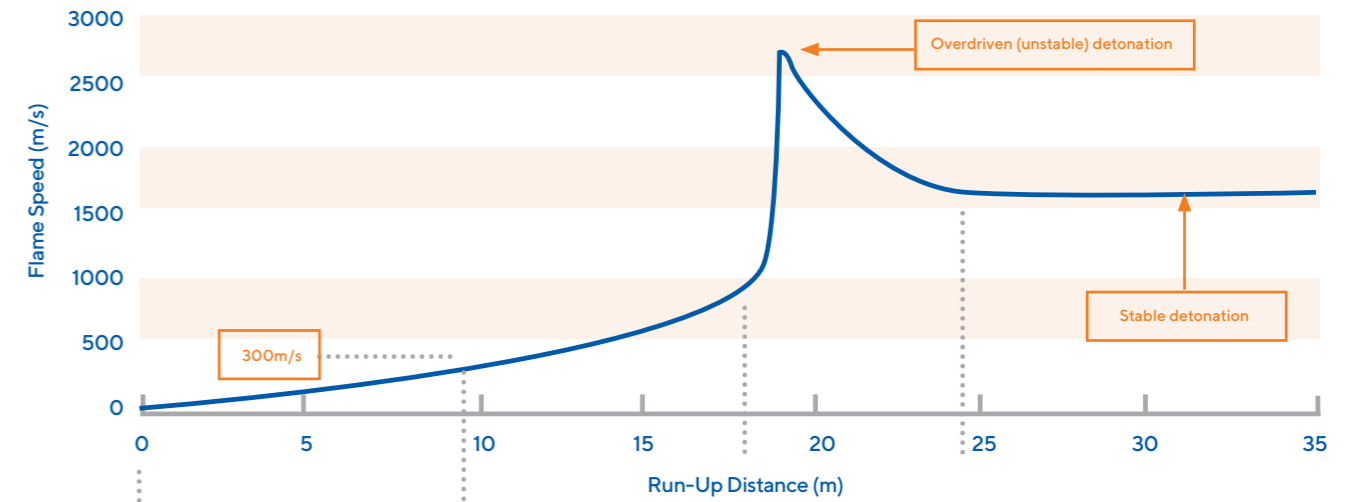

Condition	Deflagration	Fast Deflagration	Deflagration to Unstable Detonation	Stable Detonation
Flame Arrester	Deflagration	Detonation		
Location	Arresters must be located at the open end of the pipe or if in-line, within a specified maximum distance from the ignition source.	Detonation arrester can be located at any location in pipe		

The chart illustrates what typically happens to a flame front when allowed to burn unhindered down a straight pipe section with a diameter in the order of 200mm filled with a hydrocarbon gas at ambient pressure and temperature.

It can be seen from Figure 1 that the flame begins as a slow deflagration (flame speed < 300m/s), but accelerates into a fast deflagration (still at subsonic velocities ~ 500m/s).

It is recommended that a deflagration arrester is fitted as close as possible to the ignition source (within 50 pipe diameters of the arrester for hydrocarbon gases and 30 pipe diameters for hydrogen), although this distance is reduced for systems at pressures above atmospheric.

The flame then undergoes a rapid and sudden transition from deflagration to detonation. Under these conditions, the flame may accelerate to a velocity of an order of magnitude higher than the initial slow deflagration (1600m/s).

This represents the worst case conditions for the flame front and the associated pressure wave and is known as an overdriven detonation, or an unstable detonation. In such circumstances, a suitably designed unstable detonation arrester must be fitted.

An unstable detonation will degrade to a less severe stable detonation as the flame proceeds further down the pipe. However, such flame fronts may suddenly undergo further transitions to unstable conditions. These events are unpredictable, and can be caused by anything that may increase the turbulence within the system. These may include roughness on the inside surface of the pipe, a protruding gasket or instrument port and bends or constrictions due to the presence of valves etc. Due to this unpredictability, most flame arrester manufacturers recommend that an unstable detonation arrester is fitted in any pipe where a detonation may occur.

Gases & vapours

Gases and vapours vary in their flammability and explosivity. The relative severity of an explosion from a particular component mixed with air is indicated by a variety of characteristics of the gas including the lower and upper explosive limits (LEL/UEL), the auto ignition temperature (AIT), the minimum ignition energy (MIE), the limiting oxygen concentration (LOC) and the maximum experimental safe gap (MESG).

For ease of assessment, pure gases have been classified into groups of similar reactivity. Various groupings exist, depending on the source of the information but the two most widely used are shown below in tables 1 and 2. In these tables, the gas group is indicated by a range of MESG values and a typical test gas is identified for the purpose of type testing a flame arrester. If a flame arrester is satisfactorily flame tested for a given gas group then it is suitable for use with any other gas in the same group or a lower group. For example in practice propane is normally used for testing the lowest level of flame arrester and success here means that it may be used for any Group IIA gas as well as for Group I or methane. Other standards also group gases in a similar but not identical manner.

Explosion Group	MESG (mm)	Test Gas	Test Gas Concentration (% / in air)	Typical Gases
IIA	>0.90	Propane	4.2	Methane, alkanes, acetone, benzene
IIB3	≥0.65	Ethylene	6.5	Ethylene, ethylene ether
IIB	≥0.50	Hydrogen	45.0	Ethylene, butadiene
IIC	<0.50	Hydrogen	28.5	Hydrogen

Table 1 – European Standard Explosion Groups

Gas Group	MESG (mm)	Typical Gases
D	>0.75	Methane, alkanes, alcohols, acetone, benzene
C	>0.45	Ethylene, ethylene oxide
B	≤0.45	Hydrogen
A	-	Acetylene

Table 2 – NEC Gas Groups



Construction of a Flame Arrester

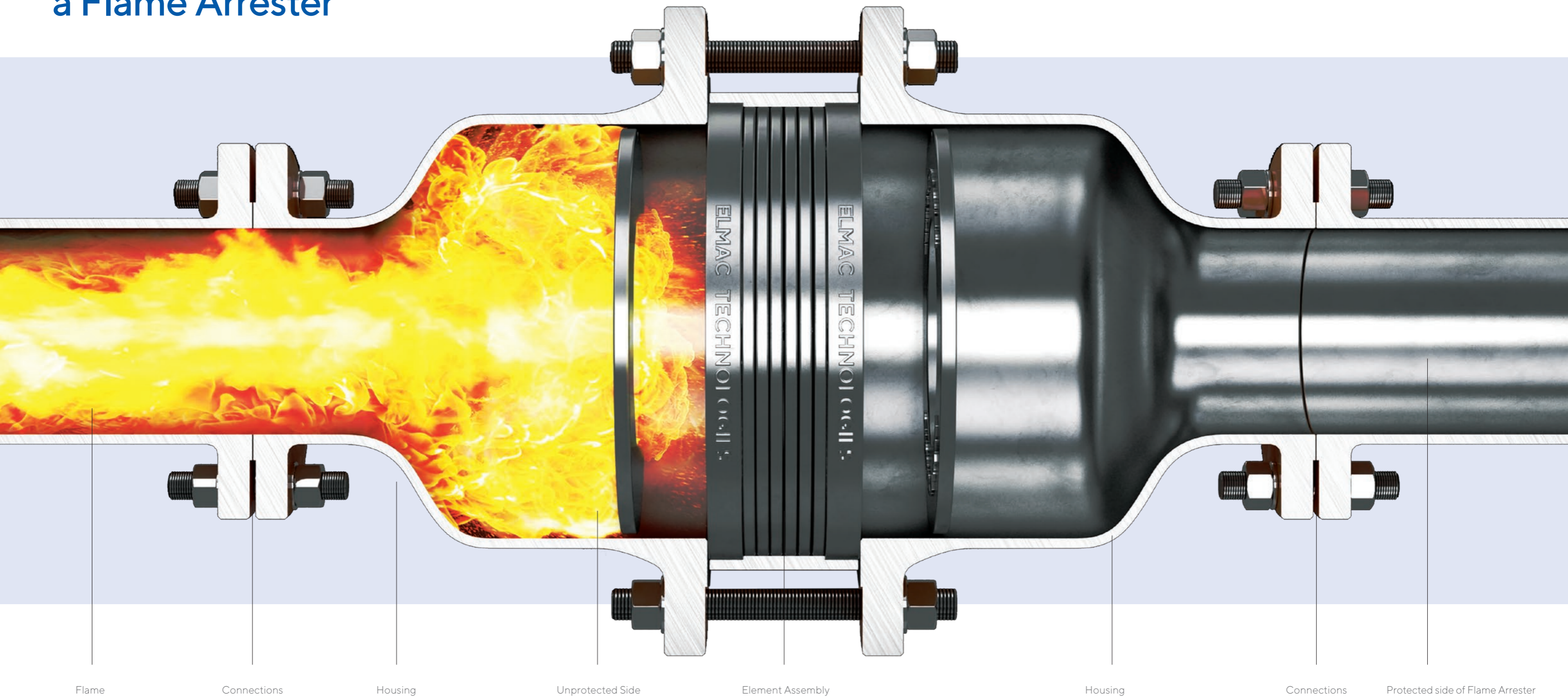

Typically a flame arrester comprises a housing, an element assembly and connection(s) to secure it to pipework or equipment. The flame arrester element assembly is the critical device that quenches the flame. The majority of element designs incorporate a "filter", comprising small apertures or cells, through which the process gas can flow but which prevent transmission of a flame.

The filter breaks down the flame front into smaller 'flamelets' that are cooled, and consequently extinguished, by the arrester element. Materials used for the "filter" element include crimped metal ribbons, woven wire gauze and sintered or honeycombed materials. Due to their design and construction, the element assembly will cause a pressure drop which is an obstruction to process flow.

In order to mitigate this increased resistance to flow, the element area is usually larger than the cross-sectional area of the pipework. The housing of the flame arrester can be integral to, or separate from, the element assembly. The end connections are typically flanged or screwed to match the adjoining pipework.

Other applications may require a different type of flame arrester including dynamic flame arresters (high velocity vent valves), hydraulic flame arresters (liquid seal) and other more specialised devices.

End-of-line Flame Arresters

This section should be read in conjunction with the attached sketches showing the principles, rather than the detailed construction, of the different types of flame arrester.

End-of-line Flame Arresters

End-of-line (EOL) flame arresters are fitted to the end of a pipeline or exit to a vessel to prevent atmospheric deflagrations (flames) from entering, and not, as is often believed, to prevent the flame exiting the vessel or pipeline. Weatherhoods are supplied to protect the flame arrester element and prevent the ingress of water and foreign debris. They are usually fitted in a vertical orientation.

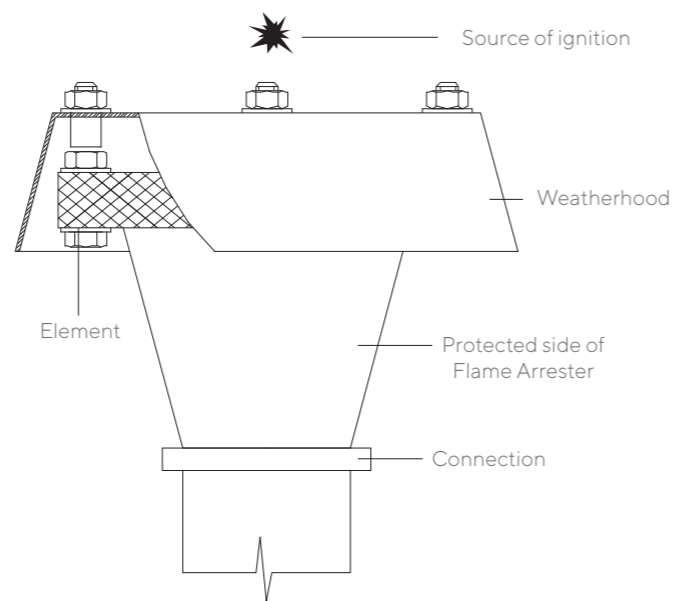
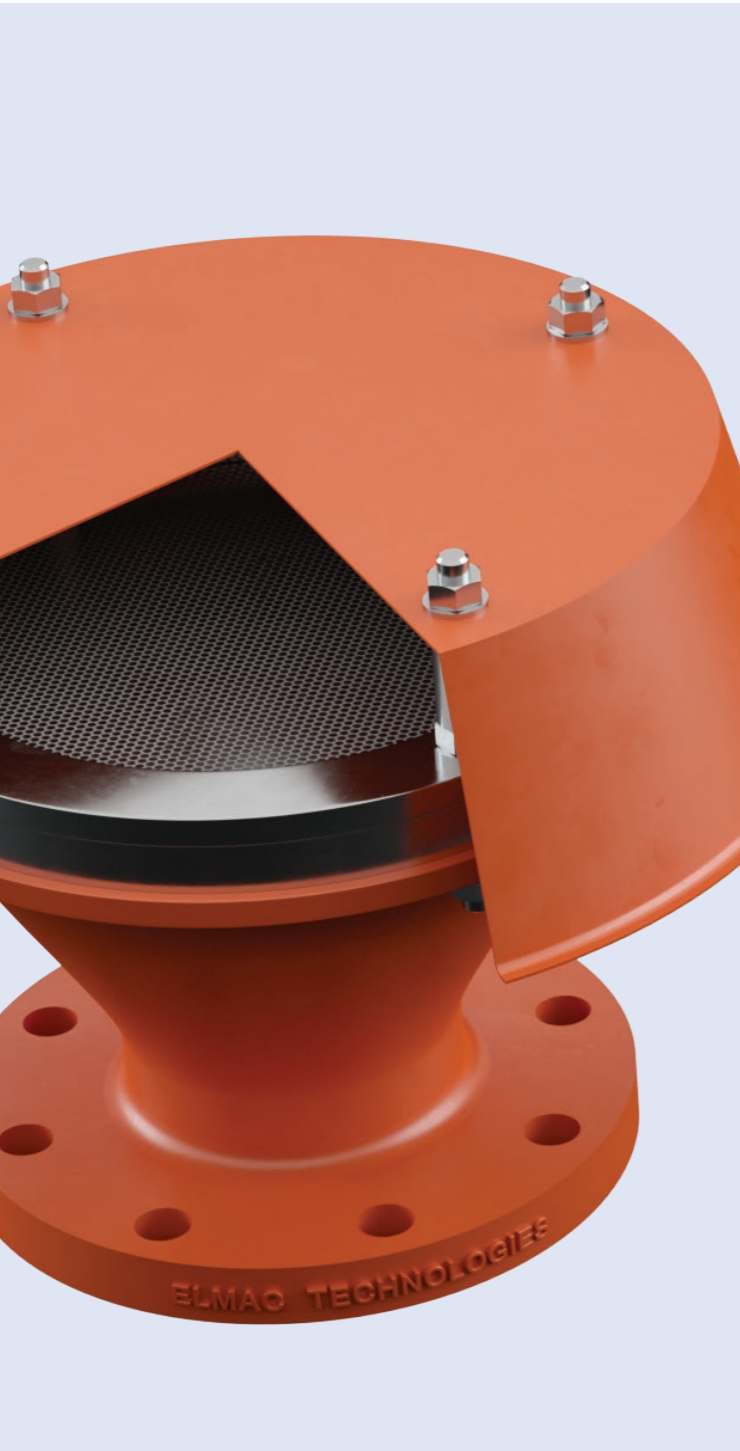

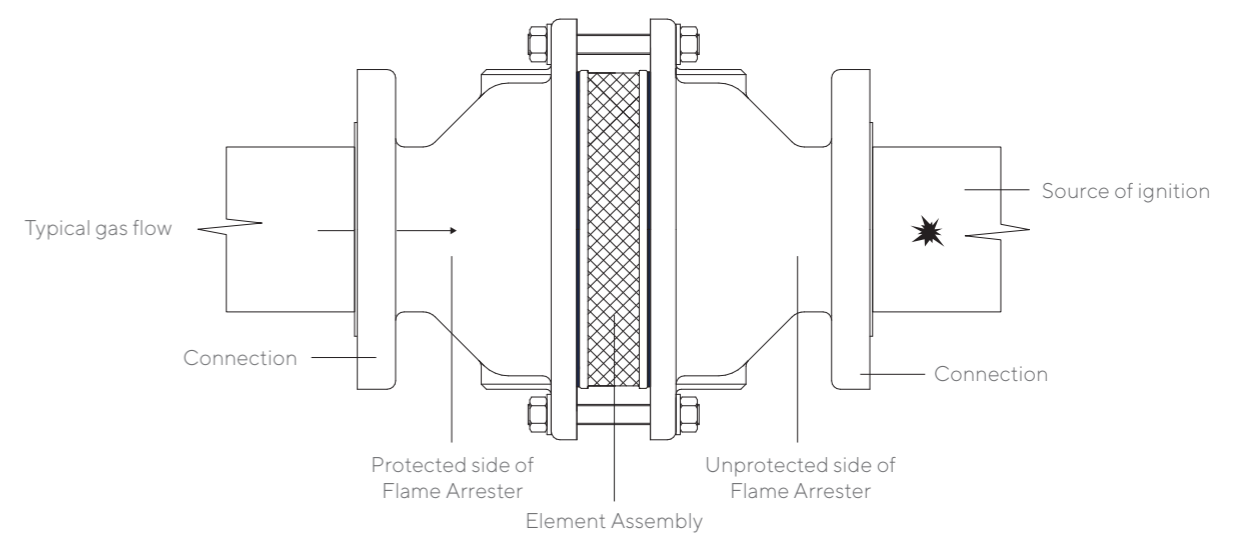

In-line Flame Arresters

In-line flame arresters are generally fitted in piping systems to protect connected equipment. The layout shown above is typical although it is also possible that the source of ignition could cause the flame to travel with the gas flow. If the flame could occur from either direction then a bi-directional flame arrester is required. In-line flame arresters can be either deflagration or detonation

arresters depending on the conditions under which they are to be used. Pipe orientation is not usually a problem unless liquid is entrained in the gas flow and possibly collecting in the bottom of the arrester. In such situations, an eccentric flame arrester housing may be fitted to facilitate collection and drainage of the liquid.

Other Types of Flame Arrester



Pre-volume Flame Arresters

These are designed to prevent flame transmission from inside to the outside of a vessel or closed pipe work system; or into the connecting pipe work after ignition by an internal ignition source. Pre-volume flame arresters are required to be tested using the original configuration or equivalent full-scale model. The use of pre-volume flame arresters will be limited to enclosures, contents and pipe work on the unprotected side as used or simulated in the tests.

Pre-volume applications

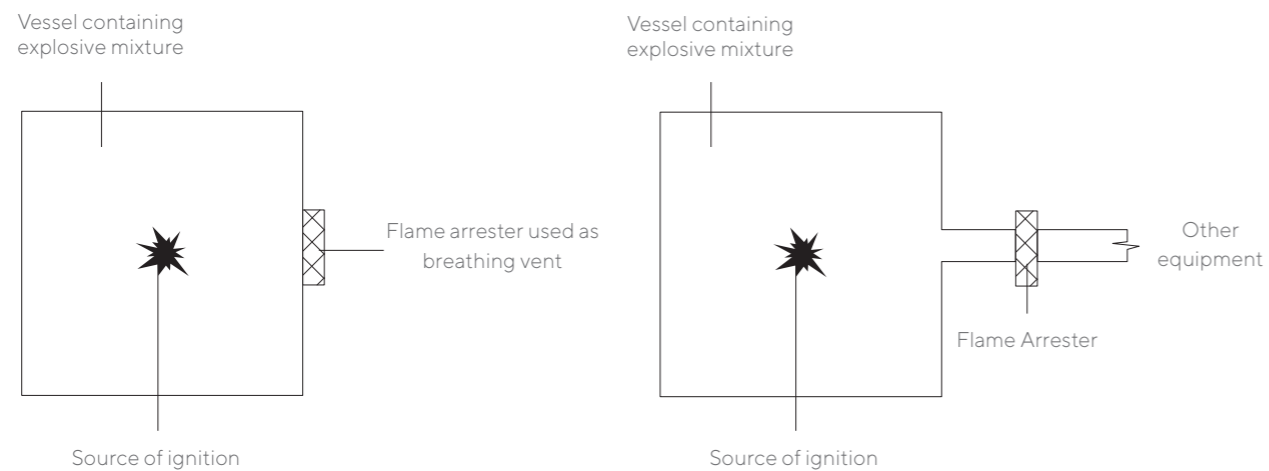

Dirt in the gas stream will collect on the element causing obstruction and increased pressure drop. Regular inspection and cleaning are strongly advised.



Flame Arresters in use

Additional protection through the use of detection and cut off systems may be required.

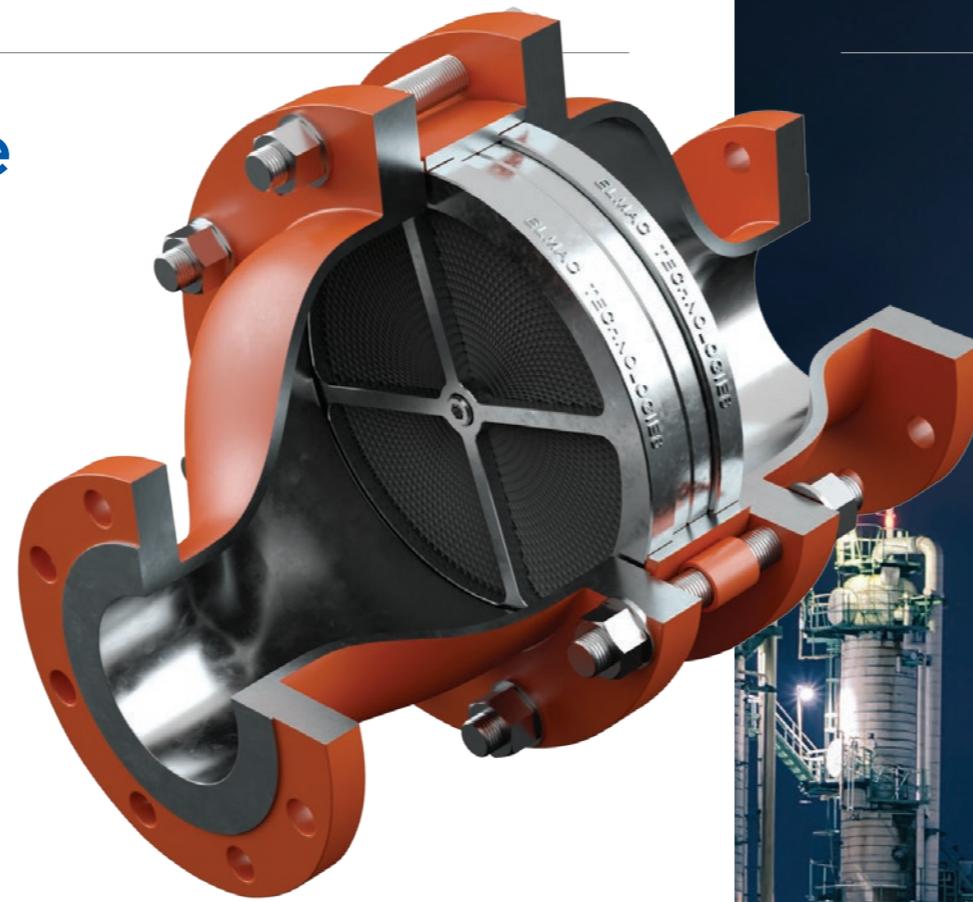

A flame arrester is required to permit process gas flow whilst extinguishing flames in the event of an explosion. A key characteristic of a flame arrester is the pressure drop or degree of obstruction to process flow due to its method of construction. This can lead to problems and it is essential that the design and sizing of the flame arrester are matched to the process flow rates and pressure drop permitted in the system, whilst simultaneously ensuring that adequate protection is provided against the consequences of accidental ignition.

Having defined where the possible source or sources of ignition may occur, and exactly what is to be protected, then the objective is to place a deflagration arrester as close as possible to the ignition source. If a flame is allowed to proceed down a pipe then, in general, it will accelerate because of pressure build up resulting from the increased temperature and volume of burnt products and become progressively more difficult to stop. Ultimately, a deflagration may undergo transition to a detonation and therefore become significantly more destructive to equipment. Where there is one or more than one source of ignition on each side of the flame arrester. A bi-directional flame arrester is required where there is one or more sources of ignition on each side of the flame arrester.

An unstable detonation flame arrester may be installed virtually anywhere in a pipework system. In order to avoid an endurance burning event, the detonation arrester can be installed some distance away from the ignition source.

If there is a continuous flow of the explosive mixture after ignition towards the unprotected side of the flame arrester, then a flame may stabilise on the flame arrester element. Stabilised burning will create additional hazards in applications and thus specially developed and tested flame arresters are required. If the flow of explosive mixture can be stopped within a specific time, then a flame arrester tested for short-time burning can be used. In those circumstances, a temperature sensor linked to an emergency system such as a gas supply cut-off system is required.

Flame arresters are usually designed for use at ambient temperature and pressure. Please consult Elmac's experienced and trained engineers for advice if other conditions are encountered. Beware of cold conditions where the element, particularly in an end-of-line unit, may freeze over and block. Higher temperatures and pressures put increased load on the flame arrester and testing under actual or simulated conditions may be required.

If corrosive or dangerous substances are present, the flame arrester may be constructed using special materials. In the majority of cases a stainless steel element together with a carbon or stainless steel housing would be adequate.

Flame arresters should be installed in accordance with the manufacturer's operating manual and should be maintained regularly, depending on the existing operating conditions. If a flash back (deflagration or detonation) is detected or a stabilised burning has occurred, the entire device needs to be checked.



Legal framework for Flame Arresters

It is recommended that products comply with the relevant standards so that insurance cover is not compromised.

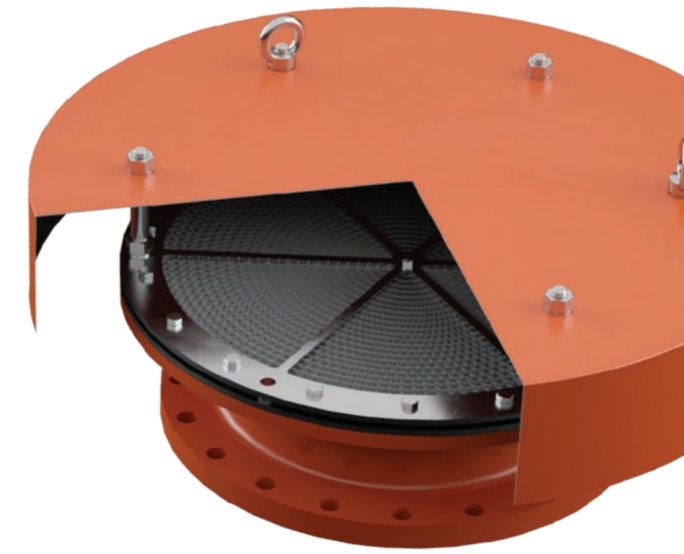

A set of European directives relating to installations in flammable and explosive atmospheres have been implemented under the general umbrella of ATEX. These directives describe the essential health and safety requirements that should be followed in industry to ensure safe, incident free operations.

There are two directives that relate directly to flame arresters: ATEX Directive 2014/34/EU (manufacturers) and Directive 1999/92/EC (plant operators). These require that products, sold for use in potentially explosive atmospheres within Europe since July 2003, must comply with certain standards of performance. In the case of flame arresters, this includes the type testing of designs to EN ISO 16852:2016 (the European standard for the design and testing of flame arresters) as well as the compliance auditing and qualification of the design and manufacturing process to ensure reliability and reproducibility of the products made.

The current international standard on flame arresters is ISO 16852:2016 (second edition). This has become mandated as the European standard, EN ISO 16852:2016. Whilst this standard is not mandatory worldwide, it is hoped that its existence will obviate the need for the many national and regional standards that currently exist. Other national standards include: US Coast Guard, Underwriters Laboratories (UL) and Factory Mutual (FM).

Furthermore, since July 2006, there has been an onus on operators of plant and equipment in explosive atmospheres to ensure that their workplaces comply with the minimum requirements of EU ATEX directive 99/92/EC. This introduces

the concept of zoning of the workplace according to the risk of explosion in each zone, and requires the operator to conduct a thorough risk assessment of the operation. It also places a responsibility to ensure that all new equipment is ATEX compliant.

Under certain circumstances, flame arresters that are fitted in-line may also be considered as pressure accessories and must therefore satisfy the minimum requirements of the Pressure Equipment Directive (PED) 2014/68/EU. Under this directive, any equipment sold above specified pressure and/or volume thresholds must be safe, meet essential safety requirements covering the design, manufacture and testing of the product and carry the CE mark indicating that it satisfies the appropriate conformity assessment procedures.



FAQs

What is a Flame Arrester?

A flame arrester (also spelt arrestor) is a safety device that is fitted to the opening of an enclosure, or to the connecting pipe work of a system of enclosures, and whose intended function is to allow flow but prevent the transmission of flame in the event an ignition takes place. Flame arresters are generally passive devices and often the last or only line of defence against flame transmission and possible catastrophic explosions.

Where are Flame Arresters used?

Flame arresters are typically used wherever there is the potential for an explosion arising from flammable gas or vapour being mixed with air. Accidental ignition of a flammable mixture will result in a flame that will travel through the unburnt mixture until the fuel is consumed by the reaction. Since a huge range of process applications are susceptible to this risk, flame arresters are utilised widely in order to protect people, plant & equipment and, of course, the environment.

How does a Flame Arrester work?

For a deflagration with no stabilised flame, the combustion products are cooled at the element surface by heat dissipation which prevents continuation of the combustion process through the flame arrester and into the protected line. In the event that a flame stabilises on the flame arrester element, a sudden increase in temperature will be detected by a monitoring system and secondary protection measures are activated to stop the flow of the flammable mixture.

Other types of flame arresters include devices that incorporate a small aperture that ensures the velocity of the gas being emitted exceeds the burning velocity of that gas thus preventing transmission of the flame. Alternatively, the gas may be bubbled through a liquid, often water, in a manner that provides a liquid barrier to flame transmission.

What is the function of the Flame Arrester element?

It is the flame arrester element that quenches the flame and the majority of designs incorporate a 'flame filter' comprising small apertures that allow the process gas to flow but prevent flame transmission. The filter breaks down the front flame into smaller 'flamelets' which are cooled by the large heat absorption capacity of the element, thus extinguishing the flame. Due to its construction, the element will cause a pressure drop or an obstruction to process flow. To mitigate this increased resistance to flow, the element area is usually larger than the cross-sectional area of the pipework.

How to specify a Flame Arrester

When specifying a flame arrester, it is important to determine three important factors: (1) the possible source(s) of ignition and what is to be protected; (2) the type of flame to be extinguished i.e. slow or fast deflagration to stable or unstable detonation; and (3) the most effective positioning of the specified flame arrester in the process - this is usually as close as possible to the ignition source. In many cases, a flame arrester is used in conjunction with other components to create a safety system. Flame arresters are designed to work in a wide range of operating and environmental conditions, so it is important to consider their installation and application limits. It is essential that the flame arrester is correctly specified to ensure that a flame is extinguished, or properly contained, and that an explosion is prevented from propagating through the equipment.

Do Flame Arresters require maintenance?

Flame arresters require regular inspection and maintenance. If a flashback is known or believed to have occurred, then the arrester should be inspected for damage. The small cells or components of the element are prone to collect dirt and become blocked thus increasing the pressure drop and reducing process gas flow. Damaged or dirty elements should be replaced. Often it is possible to clean the element for re-use. A correctly maintained flame arrester can provide many years of service.

What is a Detonation Flame Arrester?

The installation of detonation flame arresters is crucial to the safe working of offshore drilling rigs, storage & process tanks, vapour recovery units and combustion systems. They are specifically designed for pipelines with a significant distance between the ignition source and the arrester. They are also used where the pipe is rough, bent, obstructed or has section changes that result in turbulent effects and other sources of flame acceleration. This type of arrester is designed to accommodate extremely high ignition energies and the resulting pressure wave and flame front. Accordingly, in-line detonation flame arresters can be placed any distance from the ignition source and Elmac Technologies have a comprehensive range that are designed to offer the ultimate protection in these worst-case unstable detonation explosion scenarios.

What is an End-of-line Flame Arrester?

End-of-line flame arresters prevent flames from entering a vessel or pipeline. They are fitted to the end of a pipeline, or exit to a vessel, to prevent flames from entering into the pipe or vessel, from entering into the pipe or vessel and not, as is often thought, to prevent the flame exiting the pipe or vessel. Weather-hoods should always be fitted where there is exposure to rain and snow and should be mounted in a conventional, vertical orientation.

How do you prevent explosions from occurring?

Explosions depend on an atmosphere of a mixture of flammable material with oxygen. The best approach to prevent fires and explosions is to substitute or minimise the use of flammable materials. If that is not possible, it is important to avoid effective sources of ignition. The manufacturing, processing or storage of explosives is not covered in this guide.

What is a Pressure/Vacuum Relief Valve?

Pressure/Vacuum relief valves are specifically designed to protect tanks from under or over pressurisation. When correctly sized they protect against the fluctuations in pressure associated with the general operation of a storage tank i.e. thermal expansion and the normal filling/emptying cycles. Elmac Technologies also produce a full range of pressure-only and vacuum-only relief vents. Due to the process of pressure/vacuum relief vents, these products are also referred to as "breather valves".

How does a Pressure/Vacuum Relief Valve work?

A vacuum relief vent is a protection device that allows a tank to 'breathe' thus preventing collapse or rupture due to overpressure of the tank. The vacuum condition of an atmospheric tank must be controlled by allowing air to flow into the tank. They can also be used as a primary vacuum relief for normal tank breathing as it is highly accurate and avoids unwanted interaction with relief valves. Elmac recommends that the atmospheric vent of an operating tank should never be covered or blocked and that tank vents are routinely inspected for plugging when in fouling or dirty service.

For more information on any of our products, please don't hesitate to contact us.

Customer Support

Tel: +44 (0) 1352 717 555

Email: info@elmactech.com

Fax: +44 (0) 1352 717 642

Coast Road, Greenfield, Flintshire, CH8 9DP United Kingdom

All specifications are correct at time of print, are for guidance purposes only and subject to change without prior notice.



Protecting People, Property and our Planet.