

Pumps and Accessories for High Pressure Water Jetting



Industries:

- aerospace • aquaculture • automotive • chemical • construction
- demolition • energy • food & beverage • industrial cleaning
- mining • nuclear • petroleum • pharmaceuticals • pulp & paper
- quarrying • rail • highways • sewage • ship repair • steel

CALDER
A PG FLOW SOLUTIONS COMPANY



about us

From major construction and civil engineering projects, the decommissioning and decontamination of nuclear installations, the surface preparation of ships' hulls, to the removal of product contamination in chemical plant, vessels and reactors, we supply the complete range of products from waterjetting pump units to spare nozzles.

We back up our products with a huge spares stockholding, accredited training, and full service support.

Our customers use high pressure water for

- cleaning – of food conveyors, castings, tanks, reactors, vessels, pipes, tubes, tube bundles, heat exchangers, condensers, filter press, sewers, fish nets
- removal – of concrete, paint, coatings, marine growth, rubber, elastomeric, urethane, road markings
- preparation – of metal surfaces prior to painting, road surfaces, runways
- deburring, descaling, hydrostatic testing, cold cutting, steel atomization, cooling water



index

Water jet units - trailer jetters	4
Water jet units - unit options	5
Tube bundle cleaning	6
Tube bundle handling	7
PPE	8—9
Accessories - 15/20K	10
Accessories - 40K	11
Accessories - general	12—14
Surface preparation	15
Nozzle chart—Type 'A'	16

what's new



Runner Nozzle

An alternative and competitive introduction to the marketplace. Unique design. Unplugging and polishing up to 1,500 bar. The Runner Nozzle is a rotating tube cleaning nozzle, designed for cleaning heat exchanger tubes. It is available with various nozzle heads to remove hard plugs or scales.

HDP 30 Basic—high pressure waterjetting

Portable, plug-in, compact. This recent addition to the range is proving very popular across numerous industries.

Maximum operating pressure: 1,000 bar

Length: 1,324 mm

Width: 849 mm

Height: 1,328 mm

Weight: 580 kg



SpiderJet is now magnetic

The popular surface preparation tool now has a magnetic variant. The SpiderJet M attaches to the surface with two magnetic wheels which also allow maximum flexibility of movement. This unit is remotely controlled, secured by a double fall-arrest system, and the nozzle layout ensures an even distribution of HP water across the working width.

Working width: 374 mm

Max. operating pressure: 3,000 bar

Adel +966 505462688

adel.alhashim@hoeit.com



High Pressure Waterjet Units Trailer Jetters

plunger dia (mm)	working pressure psi (bar)	flow rate usgpm (lpm)
20	40,610 (2,800)	7.1 (27)
25	26,106 (1,800)	11.0 (42)
28	20,740 (1,430)	14.0 (53)
30	17,984 (1,240)	16.1 (61)
33	13,920 (960)	19.8 (75)
35	13,198 (910)	22.1 (84)
40	9862 (680)	29.3 (111)



Model 140 235 HP

Features of these units: on-board controls spark arrester overspeed valve
 inlet water filter boost pump water tank integral fuel tank direct drive
 trailer or skid conversion kits local spares stock local service team

Model 200 347 HP



plunger dia (mm)	working pressure psi (bar)	flow rate usgpm (lpm)
20	40,610 (2,800)	10.8 (41)
25	25,381 (1,750)	16.3 (62)
28	20,305 (1,400)	20.6 (78)
30	17,404 (1,200)	22.9 (87)
33	14,500 (1,000)	29.0 (110)
35	12,763 (880)	31.7 (120)
40	10,007 (690)	41.7 (158)

High Pressure Waterjet Units Unit Options

Simple pump and motor skid. Ideal for permanent installation in manufacturing and production environments.



We have various control options to suit your requirements – from basic push-button controls to comprehensive HMI touchscreen control, monitoring and data-logging functions.



This crash frame-mounted unit offers excellent protection during transportation and on-site movements. Considerable weight saving over a containerised unit.



Lightweight, compact, mobile electric unit for blasting work up to 1,000 bar. Plug-in unit—63 ampere CEE appliance plug.

In addition to a large range of pump models, performance conversion kits are available which allow the operating pressure to be changed in a short time to maximize equipment utilization.

Bespoke, lightweight units designed to suit Unimog offroad vehicle. Units contain integral hose reels and hose storage.



Maximum protection from the elements along with sound attenuation options. Moveable by crane and fork-lift truck.



Large capacity pump unit housed in a container with integral maintenance workshop.



Tube Bundle Cleaning

Our range of bundle cleaning equipment is all you need for safe, efficient tube cleaning. To suit varied industry requirements, we offer a number of internal and external tube cleaning options.

Fast, efficient internal multi rigid lance tube cleaning with the operator in control from a position away from the high pressure operation.



Freelance internal tube cleaning machine. Popular for two decades, this unit is available in single and twin-lance formats.



BUNDLEPRO

The SSC20 shell-side cleaner enables semi-automatic HP water jetting of awkward-to-reach areas via a robotic, hydraulic arm. It can be retro-fitted to a suitable vehicle and the cleaning head can be removed to allow the vehicle to return to normal duties.



The IdroBox is a lightweight, internal tube cleaner. It is a modular system which can be configured to clean three tubes at a time. Simple remote-control operation with positioning XY option.

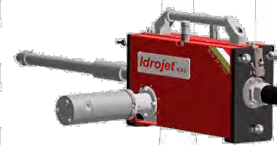

This shows two IdroBox units coupled for twin-tube cleaning.



Tube Bundle Handling



This robust, mobile, large capacity tube bundle extractor is ideal for multi-site operations. Tube bundles can be extracted and moved with the minimum of effort.

This hook-lift extractor's tube pull/push operations are achieved through its integrated power unit. Hydraulic operation is through remote control. A self-balance capability ensures the load and machine are balanced.



The bundle arm lift unit is a new design capable of lifting tube bundles up to 50,000 kg

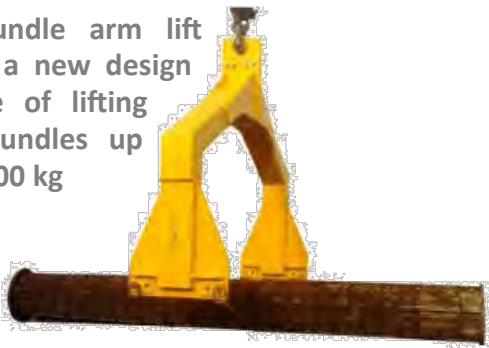

Our bundle handling equipment includes versatile extractors and movers for the removal and re-insertion of bundles both large and small. Our bundle movers range from the simple lift arm to the mobile straddle carrier.

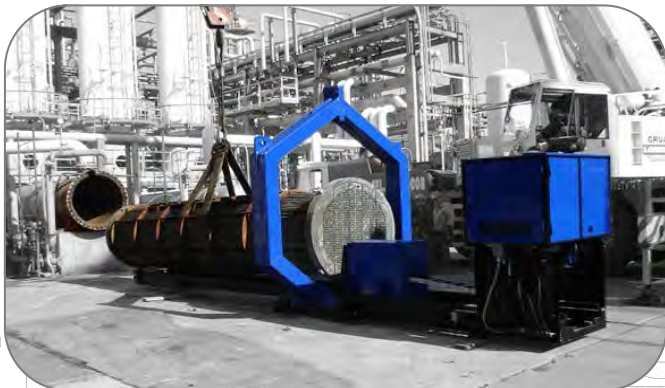

This versatile, remotely controlled extractor is designed for manoeuvrability. This self-contained unit handles a range of bundle sizes and operates at height.

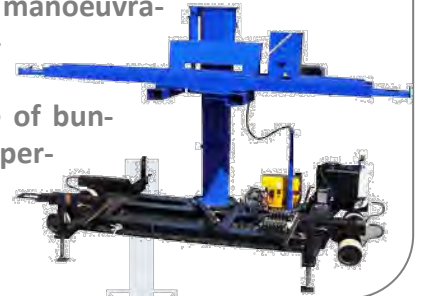

Truck-mounted extractor. In addition to the usual features of our extractors, this road-going machine can be used at various locations reducing replication of machines across different sites.



This straddle carrier is designed specifically for the onsite movement of a large range of tube bundles up to 20,000 kg. A 5-speed gearbox, dual circuit air brakes and power steering make this unit very operator friendly.



Adel +966 505462688
adel.alhashim@hoeit.com

HOEIT

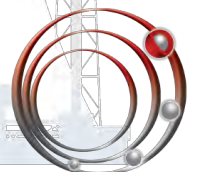

PPE

Pro-Operator 500 bar jacket and trousers.

Jacket:

- lined for comfort
- adjustable waist
- ventilated
- inside pocket
- outside pockets
- pocket for phone
- ID pocket on sleeve
- water repellent
- dirt repellent
- hi-vis option



Trousers:

- waterproof pocket on leg
- pockets for knee pads
- knife pocket on leg
- detachable braces

Bib & Brace Trousers up to 3,000 bar

- full front protection
- adjustable braces
- stretch material
- belt support

For warm environments trousers available with ventilation to distribute fresh air in the legs and in the front. Air compressor hook up required.



Waterproof gloves

- 500 bar
- separate inner gloves for comfort
- rough sand-patterned surface for good grip



Pro-Operator high visibility options up to 500 bar



We supply only the best quality personal protective equipment. There is a huge range of items to suit the application and the operator's preferences. If you can't see it here, give us a call on +44 1905 751790



Boots 3000

- up to 3,000 bar
- fixed aluminium gaiters
- comfortable



CALDER

A PG FLOW SOLUTIONS COMPANY

www.calder.co.uk

PPE

Helmet 20/30

All parts are tested and certified for protection against liquids with pressure up to 3,000 bar / 43500 psi.



Hose restraint (Chinese Fingers) Range of sizes



Hose protector —
3,000 bar
Effective protection
for the operator



Economical option which can be used by various operators. Adjustable for comfort. Can be upfolded.



Yellow boots

- 800 bar
- lightweight
- economic



Gaiters

- lightweight
- adjustable

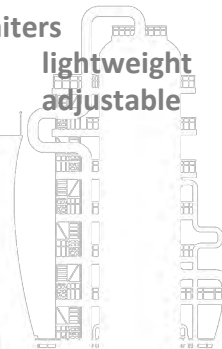

Accessories 15/20K

Pressure regulating valves 15/20K



20K Hand-held dump gun

- lightweight
- adjustable



Flow divider c/w pressure gauge



Foot pedal 15/20K

- easy valve replacement
- smooth operation
- reliable



Ergonomic trigger 15/20/40K



RPCD 1,500 bar pipe cleaning



This rotating device is designed for cleaning pipes with hard-crusting deposits.

Hand-held dump gun 15K

- adjustable, contoured shoulder stock
- stainless steel working components



Accessories 40K

Foot pedal 40K

- easy valve replacement
- smooth operation
- reliable



Tumble box/Trimode valve

- 2,800 bar
- easy wear part replacement
- fail-safe design
- air isolator
- 15 kg



Hand-held dump gun 40K

- lightweight
- adjustable



Hose catcher (basic)

- flange mounted
- stainless steel



for the cleaning of

- heat exchangers
- large pipes up to 400 mm
- vertical and horizontal use

Zero thrust gun for underwater use

- can also be used on dry land
- quick change cartridge



Hose catcher (chicken wing)

- tube sheet mounting
- splashguard
- inserts to change size

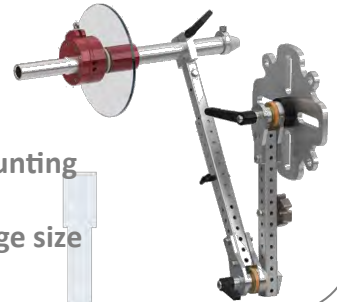

Pressure regulating valve 40K can be adjusted whilst under load

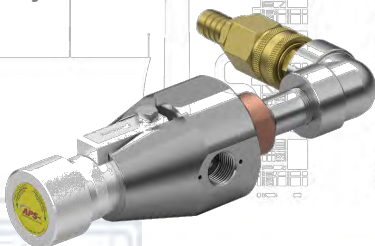

Adel +966 505462688
adel.alhashim@hoeit.com

HOEIT



Accessories

Tube bundle roller

- suits a large range of bundle sizes
- four rollers
- stainless steel
- easy transport



Hose collector drum

- rolling up/down live hoses
- lightweight aluminium/plastic construction
- suitable for multiple hoses
- 1,500 bar



Centralizers

- easy to adjust, easy to use
- optimal alignment
- stainless steel



Rotary swivel coupling

- powered rotation
- air or hydraulic
- safety hood
- 1,500 bar



Sewer razor

- adjustable rotation speed
- DI 14 jets with sharp, hard-hitting jets
- stainless steel
- 400 bar



Rigid lance cleaning system

- removal of hard plugs and scaling
- modular design
- adaptable length
- safe and fast cleaning

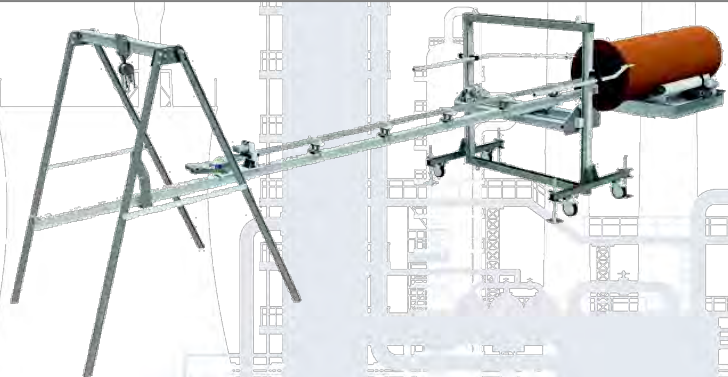

Accessories

Shell side blaster

- adjustable height
- easy to use
- easy to transport
- multiple nozzle options

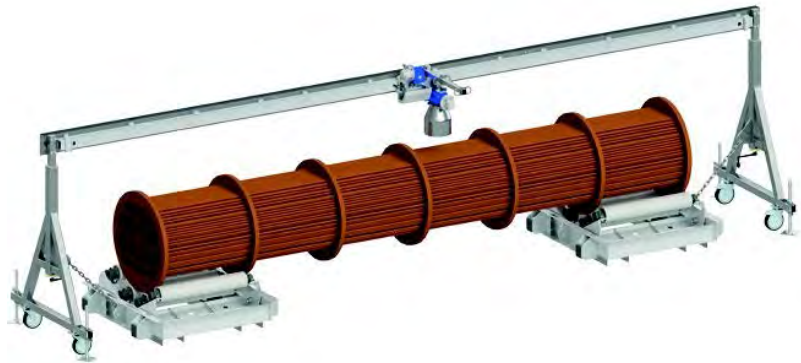

Rotary coupling swivel

- low maintenance
- stainless steel
- 1,500 bar



Rotary coupling swivel

- stainless steel
- metric and UNF connections
- 3,000 bar



Automated solutions rail

- maintenance-free rollers
- 2.5" or 4" models



Automated solutions tractors

- easy to control linear speeds
- air or hydraulic powered
- possible upgrade to PLC
- suitable for 2.5" or 4" aluminium rails

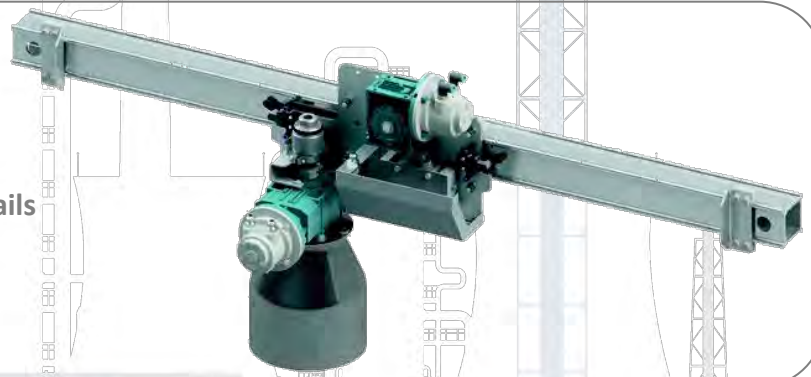

Accessories

RD Master surface prep nozzle

- lightweight—1 kg
- options up to 3,200 bar
- speed adjustable by hand
- variable speed
- easy maintenance
- high performance seal system



Speed regulated pipe/tube cleaner

- cleaning pipes and vessels
- unplugging and clearing pipes
- adjustable speed
- 1,500 bar

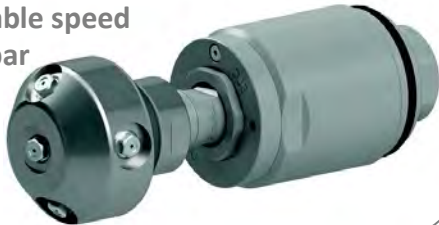

Runner nozzle

- unplugging or polishing tubes/pipes
- unique design
- 1,500 bar



Speed regulated pipe cleaner

- compact, short design
- adjustable speed
- stainless steel
- 1,500 bar



Abrasive cutting nozzle

- 4,000 bar max W.P.
- 10-25 lpm
- concrete cutting
- steelwork cutting
- range of nozzles available to suit various applications



Rotating surface prep nozzle

- 1,000 bar
- 60 lpm
- 1000-2000 rpm
- 1.6 kg
- Proven reliability in the field over many years

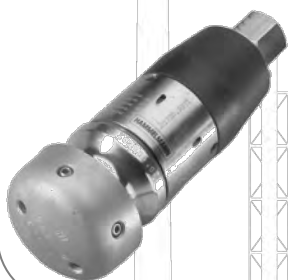

3D Tank cleaning head

- pressures up to 1,600 bar
- flows up to 500 lpm
- large range available
- chemical industry options



Surface preparation Automation

A key Calder focus is removing the operator from the hazards of water jetting operations such as high reaction forces and high water pressures.

Below is a small selection of the products available to help keep your colleagues safe.

SpiderJet

Surface preparation for storage tanks, ships, and most large areas.

- magnetic and vacuum options
- vacuum recovery options
- working width 374 mm
- 3,000 bar
- 50 lpm



Surface cleaner

- 3,000 bar
- up to 40 lpm
- up to 2,500 rpm
- working width 215 mm

The waste water can be removed by vacuum to a filter unit for separation/disposal/re-use

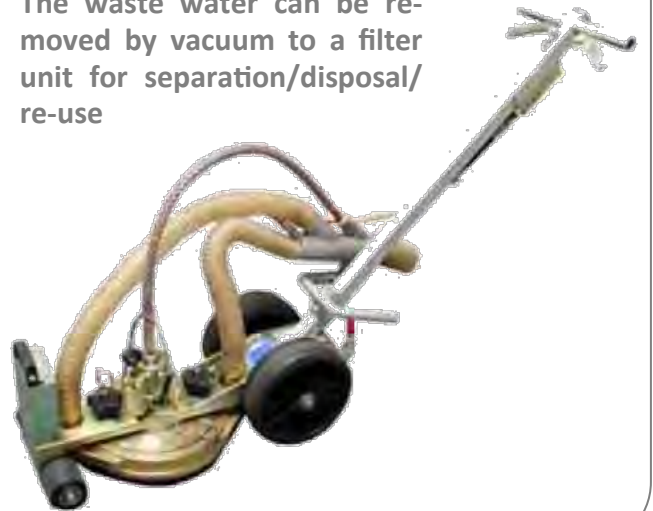

Work on ceilings and undersides



Work on floors



Jetboy

- work overhead
- work on the floor
- versatile
- minimises operator exposure to reaction force

Mechanical assistance for manual gun work—keep your operators safe

Adel +966 505462688
adel.alhashim@hoeit.com

HOEIT

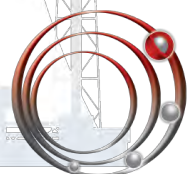

Type 'A' Nozzle Chart—efficiency factor 0.95



m/s	Nozzle Ø (mm)																							
	0.4	0.5	0.6	0.7	0.8	0.9	1	1.1	1.2	1.3	1.4	1.5	1.6	1.7	1.8	1.9	2	2.1	2.2	2.3	2.4	2.5		
800	388.3	lpm	2.8	4.4	6.4	8.7	11.3	14.3	17.7	21.4	25.5	29.9	34.7	39.8	45.3	51.2	57.4	63.9	70.8	78.1	85.7	93.7	102.0	110.7
850	400.3	lpm	18.7	29.2	42.1	57.3	74.8	94.7	116.9	141.4	168.3	197.6	229.1	263.0	299.3	337.8	378.8	422.0	467.6	515.5	565.8	618.4	673.3	730.6
900	411.9	lpm	2.9	4.6	6.6	8.9	11.7	14.8	18.3	22.1	26.3	30.8	35.8	41.1	46.7	52.7	59.1	65.9	73.0	80.5	88.3	96.6	105.1	114.1
950	423.2	lpm	19.9	31.1	44.7	60.9	79.5	100.6	124.2	150.3	178.9	209.9	243.4	279.5	318.0	359.0	402.4	448.4	496.8	547.7	601.2	657.0	715.4	776.3
1000	434.2	lpm	3.0	4.7	6.8	9.2	12.0	15.2	18.8	22.7	27.0	31.7	36.8	42.3	48.1	54.3	60.9	67.8	75.1	82.8	90.9	99.4	108.2	117.4
1100	455.4	lpm	21.0	32.9	47.3	64.4	84.2	106.5	131.5	159.1	189.4	222.3	257.8	295.9	336.7	380.1	426.1	474.8	526.0	580.0	636.5	695.7	757.5	821.9
1200	475.6	lpm	3.1	4.8	6.9	9.5	12.3	15.6	19.3	23.3	27.8	32.6	37.8	43.4	49.4	55.8	62.5	69.7	77.2	85.1	93.4	102.1	111.1	120.6
1300	495.0	lpm	22.2	34.7	50.0	68.0	88.8	112.4	138.8	168.0	199.9	234.6	272.1	312.3	355.4	401.2	449.8	501.1	555.3	612.2	671.9	734.3	799.6	867.6
1400	513.7	lpm	3.2	4.9	7.1	9.7	12.7	16.0	19.8	24.0	28.5	33.5	38.8	44.5	50.7	57.2	64.1	71.5	79.2	87.3	95.8	104.7	114.0	123.7
1500	531.8	lpm	23.4	36.5	52.6	71.6	93.5	118.4	146.1	176.8	210.4	246.9	286.4	328.8	374.1	422.3	473.4	527.5	584.5	644.4	707.2	773.0	841.7	913.3
1600	549.2	lpm	3.3	5.2	7.5	10.2	13.3	16.8	20.8	25.1	29.9	35.1	40.7	46.7	53.2	60.0	67.3	75.0	83.1	91.6	100.5	109.8	119.6	129.8
1700	566.1	lpm	25.7	40.2	57.9	78.8	102.9	130.2	160.7	194.5	231.5	271.6	315.0	361.7	411.5	464.5	520.8	580.3	642.9	708.8	778.0	850.3	925.8	1005.0
1800	582.5	lpm	3.5	5.4	7.8	10.6	13.9	17.6	21.7	26.2	31.2	36.7	42.5	48.8	55.5	62.7	70.3	78.3	86.7	95.6	105.0	114.7	124.9	135.5
1900	598.5	lpm	28.1	43.8	63.1	85.9	112.2	142.0	175.3	212.2	252.5	296.3	343.7	394.5	448.9	506.8	568.1	633.0	701.4	773.3	848.7	927.6	1010.0	1096.0
2000	614	lpm	3.6	5.6	8.1	11.1	14.4	18.3	22.6	27.3	32.5	38.1	44.2	50.8	57.8	65.2	73.1	81.5	90.3	99.5	109.3	119.4	130.0	141.1
2100	629.2	lpm	30.4	47.5	68.4	93.1	121.6	153.9	190.0	229.9	273.5	321.0	372.3	427.4	486.3	549.0	615.5	685.8	759.8	837.7	919.4	1005.0	1094.0	1187.0
2200	644	lpm	3.7	5.9	8.4	11.5	15.0	19.0	23.4	28.3	33.7	39.6	45.9	52.7	60.0	67.7	75.9	84.6	93.7	103.3	113.4	123.9	134.9	146.4
2300	658.5	lpm	32.7	51.1	73.6	100.2	130.9	165.7	204.6	247.5	294.6	345.7	401.0	460.3	523.7	591.2	662.8	738.5	818.3	902.2	990.1	1082.0	1178.0	1279.0
2400	672.6	lpm	3.9	6.1	8.7	11.9	15.5	19.6	24.2	29.3	34.9	41.0	47.5	54.6	62.1	70.1	78.6	87.5	97.0	106.9	117.4	128.3	139.7	151.5
2500	686.5	lpm	35.1	54.8	78.9	107.4	140.3	177.5	219.2	265.2	315.6	370.4	429.6	493.2	561.1	633.4	710.2	791.3	876.7	966.6	1061.0	1159.0	1263.0	1370.0
		lpm	4.0	6.3	9.0	12.3	16.0	20.3	25.0	30.3	36.1	42.3	49.1	56.3	64.1	72.4	81.1	90.4	100.2	110.4	121.2	132.5	144.2	156.5
		lpm	37.4	58.4	84.2	114.6	149.6	189.4	233.8	282.9	336.7	395.1	458.2	526.0	598.5	675.7	757.5	844.0	935.2	1031.0	1132.0	1237.0	1347.0	1461.0
		lpm	4.1	6.5	9.3	12.6	16.5	20.9	25.8	31.2	37.2	43.6	50.6	58.1	66.1	74.6	83.6	93.2	103.3	113.8	124.9	136.5	148.7	161.3
		lpm	39.7	62.1	89.4	121.7	159.0	201.2	248.4	300.6	357.7	419.8	486.9	558.9	635.9	717.9	804.9	896.8	993.6	1095.0	1202.0	1314.0	1431.0	1553.0
		lpm	4.2	6.6	9.6	13.0	17.0	21.5	26.6	32.1	38.2	44.9	52.1	59.8	68.0	76.8	86.1	95.9	106.2	117.1	128.6	140.5	153.0	166.0
		lpm	42.1	65.8	94.7	128.9	168.3	213.0	263.0	318.3	378.8	444.5	515.5	591.8	673.3	760.1	852.2	949.5	1052.0	1160.0	1273.0	1391.0	1515.0	1644.0
		lpm	4.4	6.8	9.8	13.4	17.5	22.1	27.3	33.0	39.3	46.1	53.5	61.4	69.9	78.9	88.4	98.5	109.2	120.3	132.1	144.4	157.2	170.6
		lpm	44.4	69.4	99.9	136.0	177.7	224.9	277.6	335.9	399.8	469.2	544.2	624.7	710.7	802.4	899.5	1002.0	1111.0	1224.0	1344.0	1469.0	1599.0	1735.0
	614	lpm	4.5	7.0	10.1	13.7	17.9	22.7	28.0	33.9	40.3	47.3	54.9	63.0	71.7	80.9	90.7	101.1	112.0	123.5	135.5	148.1	161.3	175.0
		lpm	46.8	73.1	105.2	143.2	187.0	236.7	292.2	353.6	420.8	493.9	572.8	657.6	748.2	844.6	946.9	1055.0	1169.0	1289.0	1414.0	1546.0	1683.0	1827.0
		lpm	4.6	7.2	10.3	14.1	18.4	23.2	28.7	34.7	41.3	48.5	56.2	64.6	73.4	82.9	93.0	103.6	114.8	126.5	138.9	151.8	165.2	179.3
		lpm	49.1	76.7	110.5	150.4	196.4	248.6	306.9	371.3	441.9	518.6	601.4	690.4	785.6	886.8	994.2	1108.0	1227.0	1353.0	1485.0	1623.0	1768.0	1918.0
		lpm	4.7	7.3	10.6	14.4	18.8	23.8	29.4	35.5	42.3	49.6	57.6	66.1	75.2	84.9	95.1	106.0	117.5	129.5	142.1	155.3	169.1	183.5
		lpm	51.4	80.4	115.7	157.5	205.7	260.4	321.5	389.0	462.9	543.3	630.1	723.3	823.0	929.1	1042.0	1161.0	1286.0	1418.0	1556.0	1701.0	1852.0	2009.0
		lpm	4.8	7.5	10.8	14.7	19.2	24.3	30.0	36.3	43.2	50.7	58.8	67.6	76.9	86.8	97.3	108.4	120.1	132.4	145.3	158.8	172.9	187.7
		lpm	53.8	84.0	121.0	164.7	215.1	272.2	336.1	406.7	484.0	568.0	658.7	756.2	860.4	971.3	1089.0	1213.0	1344.0	1482.0	1627.0	1778.0	1936.0	2101.0
		lpm	4.9	7.7	11.0	15.0	19.6	24.8	30.7	37.1	44.2	51.8	60.1	69.0	78.5	88.6	99.4	110.7	122.7	135.3	148.4	162.7	176.7	191.7
		lpm	56.1	87.7	126.3	171.8	224.4	284.1	350.7	424.3	505.0	592.7	687.4	789.1	897.8	1014.0	1136.0	1266.0	1403.0	1547.0	1697.0	1855.0	2020.0	2192.0
		lpm	5.0	7.8	11.3	15.3	20.0	25.4	31.3	37.9	45.1	52.9	61.4	70.4	80.1	90.5	101.4	113.0	125.2	138.0	151.5	165.6	180.3	195.6
		lpm	58.4	91.3	131.5	179.0	233.8	295.9	365.3	442.0	526.0	617.4	716.0	821.9	935.2	1056.0	1184.0	1319.0	1461.0	1611.0	1768.0	1932.0	2104.0	2283.0

reaction force > 150 N

reaction force > 250 N

www.calderltd.com
sales@calder.co.uk
+44 (0) 1905 759090

Calder Ltd, Prescott Drive, Worcester, WR4 9NE, UK